



INDIAN SCHOOL AL WADI AL KABIR



CLASS: VII	DEPARTMENT: SCIENCE 2023 – 2024	DATE: 05.06.2023
TEXTBOOK Q & A	TOPIC: ELECTRIC CURRENT AND ITS EFFECTS	NOTE: A4 FILE FORMAT
NAME OF THE STUDENT:	CLASS & SEC:	ROLL NO.

1. Draw in your notebook the symbols to represent the following components of electrical circuits: connecting wires, switch in the 'OFF' position, bulb, cell, switch in the 'ON' position, and battery.

Component of electrical circuit	Symbols
Connecting wires	
Switch in the 'OFF' position	
Bulb	
Cell	
Switch in the 'ON' position	
Battery	

2. Draw the circuit diagram to represent the circuit shown in the figure.

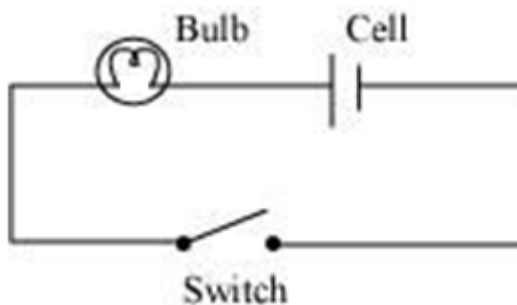

3. Figure shows four cells fixed on a board. Draw lines to indicate how you will connect their terminals with wires to make a battery of four cells.



Ans: To make a battery, the negative terminal of one cell must be connected to the positive terminal of the next cell. The wire indicates the manner in which the given cells should be connected with each other, as shown in the following figure.

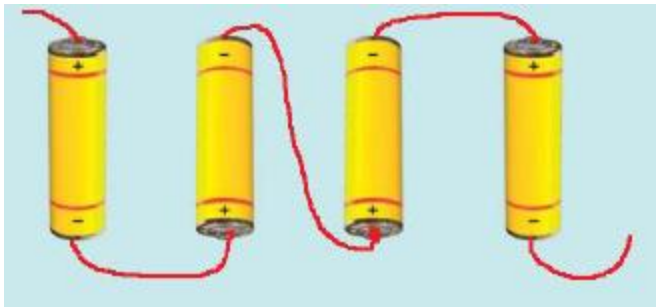

4. The bulb in the circuit shown in Figure does not glow. Can you identify the problem? Make necessary changes in the circuit to make the bulb glow.

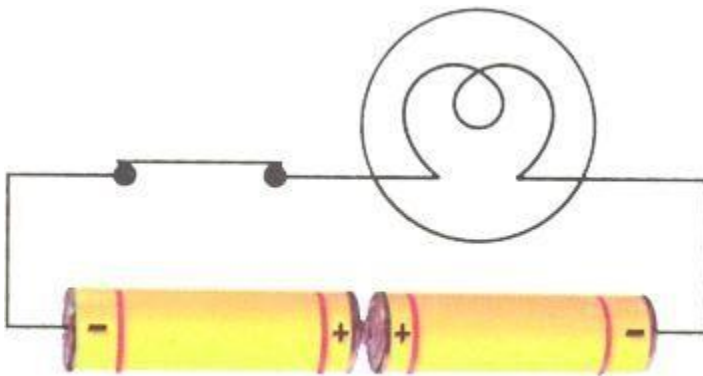

Ans: The bulb in the circuit is not glowing because the two cells are not connected properly.

To make the bulb glow, the negative terminal of one cell should be connected to the positive terminal of the other cell, as shown in the given figure.

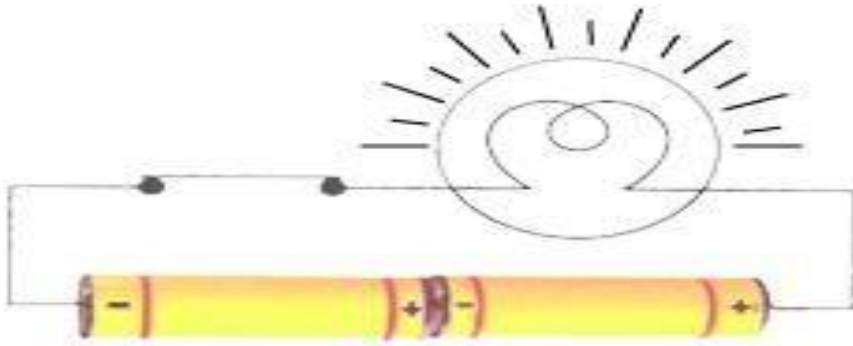

5. Name any two effects of electric current.

Ans: The two effects of electric current are: (i) the Heating effect of electric current; (the ii) Magnetic effect of electric current.

6. When the current is switched on through a wire, a compass needle kept nearby gets deflected from its north-south position. Explain.

Ans: When the current is switched on through a wire, a magnetic field is created around it hence we see deflection in the compass needle kept nearby.

7. Will the compass needle show deflection when the switch in the circuit shown by figure is closed?

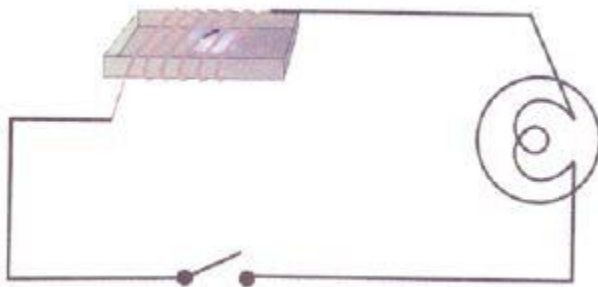

Ans: No. The given circuit does not have any current source. In the absence of current, the wire does not behave as a magnet and hence, the compass needle will not show any deflection.

8. Fill in the blanks:

(a) Longer line in the symbol for a cell represents its _____ terminal. **(positive)**

(b) The combination of two or more cells is called a _____. **(battery)**

- (c) When current is switched 'on' in a room heater, it _____. (**becomes red hot**)
- (d) The safety device based on the heating effect of electric current is called a _____. (**fuse**)

9. Mark 'T' if the statement is true and 'F' if it is false:

- (a) To make a battery of two cells, the negative terminal of one cell is connected to the negative terminal of the other cell. (**F**)
- (b) When the electric current through the fuse exceeds a certain limit, the fuse wire melts and breaks. (**T**)
- (c) An electromagnet does not attract a piece of iron. (**F**)
- (d) An electric bell has an electromagnet. (**T**)

10. Do you think an electromagnet can be used for separating plastic bags from a garbage heap? Explain.

Ans: No. Electromagnets can only attract magnetic materials. The plastic bag is a non-magnetic material and will not be attracted by an electromagnet. Hence, an electromagnet cannot be used for separating plastic bags from a garbage heap.

11. An electrician is carrying out some repairs in your house. He wants to replace a fuse with a piece of wire. Would you agree? Give reasons for your response.

Ans: No. The electrician cannot be allowed to replace the fuse in the house with a piece of wire. Because every wire cannot be used as a fuse filament. A fuse filament must have a low melting point such that it could melt and break in response of a large amount of current. Most of the wires have high melting points.

12. Zubeda made an electric circuit using a cell holder shown in Fig. 14.4, a switch and a bulb. When she put the switch in the 'ON' position, the bulb did not glow. Help Zubeda in identifying the possible defects in the circuit.



Ans: One of the reasons may be that the rubber band used in the cell holder may not be tight enough to keep the two cells in contact with each other. If the cells are not in proper contact with each other, then the circuit will not be complete and current will not flow through the circuit. Hence, the bulb will not glow. The other reason may be that the two cells are not connected properly. The negative terminal of one cell must be connected to the positive terminal of the other cell. Another reason may be the fused bulb.

13. In the circuit shown in the figure

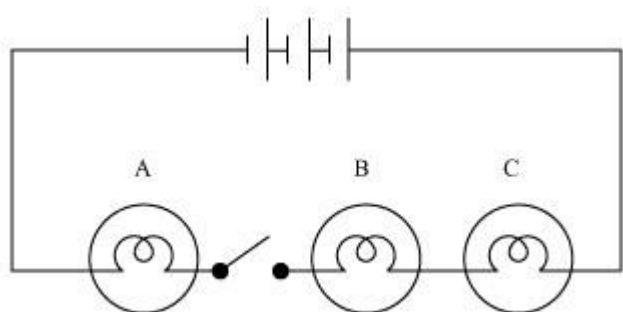

- (i) Would any of the bulbs glow when the switch is in the 'OFF' position?

Ans: No. When the switch is in the 'OFF' position, the current does not flow through the circuit. Hence, none of the bulbs will glow.

- (ii) What will be the order in which the bulbs A, B and C will glow when the switch is moved to the 'ON' position?

Ans: Bulbs will glow simultaneously because they all are connected to the same battery and switch.

Prepared By: Ms. Neena Alex	Checked by: HOD – SCIENCE & FRENCH
--------------------------------	---------------------------------------